



# CUTTING SOLUTIONS

Products Overview

**FIBERLINE**  
**OMNIA**  
**LINEA**  
**PLASMA**  
**TUBOCUT**  
**WATEJET**





## COMPANY

Since its founding in 1938, the SOITAAB Group has grown to become a world-leading manufacturer of CNC industrial cutting machines. Our greatest challenge is to always focus on technological innovation, which has enabled us to become one of the global leaders in the field of CNC industrial cutting machines. The technologies we have developed and our production lines for plasma, flame, waterjet, laser, and bandsaw machines work in perfect harmony and interaction. SOITAAB offers the widest range of cutting technologies available on the market a competitive advantage that allows us to grow steadily and provide our customers with the most comprehensive and flexible technological solutions.

## MISSION

### Technological Innovation

With over 85 years of experience in the field, SOITAAB believes in continuous technological development and the constant pursuit of innovative cutting solutions, aiming to consistently achieve the highest levels of efficiency, precision, and speed.

### Quality and Efficiency of Production Processes.

Thanks to its modern facilities in Milan, SOITAAB manages every aspect of production in-house, from design and mechanical processing to assembly and testing of each product. This unique and meticulous process ensures the highest quality and efficiency.

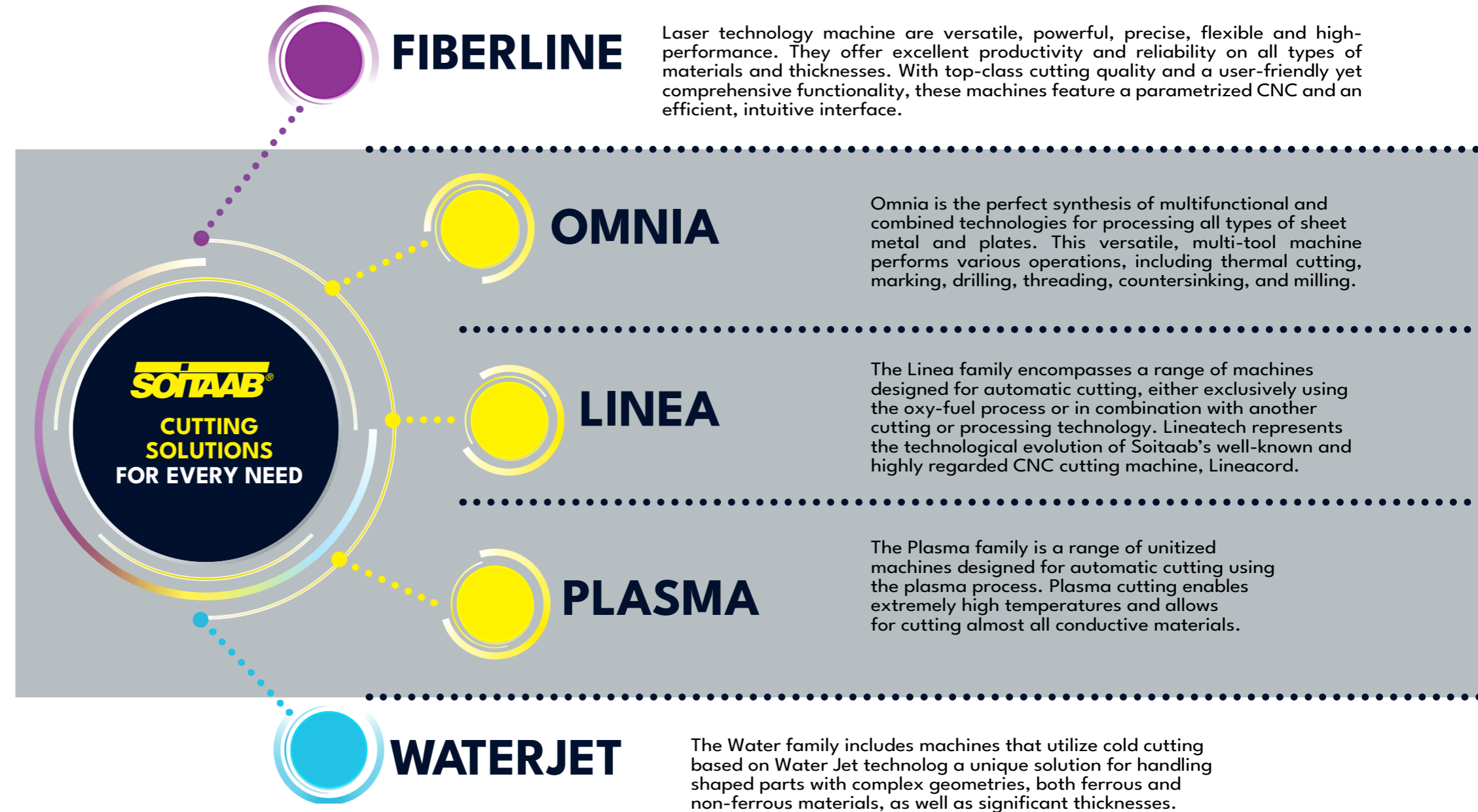

# FIBERLINE



Drilling Head  
Maximum Drilling Diameter: 30 mm  
Tapping Capacity: M24



5-Axis Bevel Head



3-Axis Laser Head

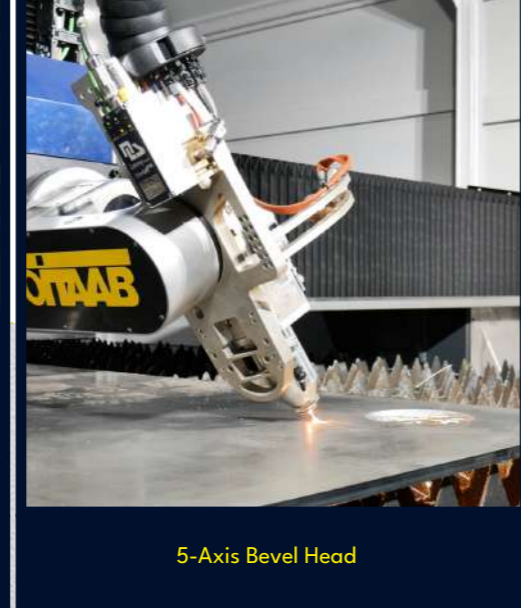
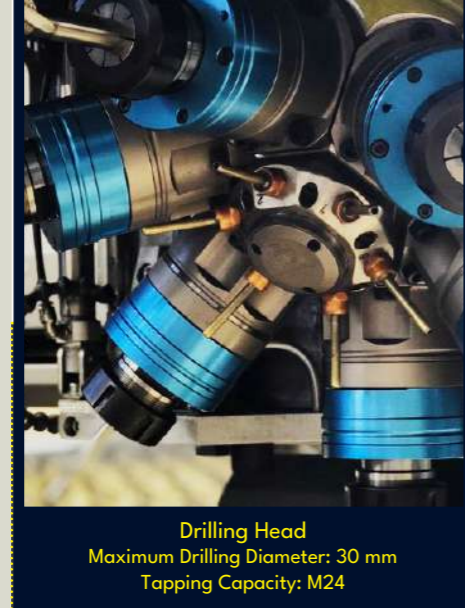

## FIBERLINE VICTORY

The new Fiberline Victory represents a remarkable innovation in the field of laser cutting machines. This system features a beam that moves independently from the cabin, enabling unprecedented flexibility and precision. At the same time, the cabin automatically adapts to the beam's movements, ensuring smooth and safe operation. This synergy between the beam and the cabin optimizes performance and enhances production efficiency, making the Fiberline Victory an ideal choice for companies seeking advanced technology and reliability.

### OPERATIONS

DRILLING



MARKING



LASER CUTTING

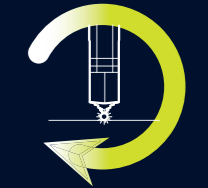

# FIBERLINE



## FIBERLINE EXPERT

The **EXPERT** represents the compact and versatile version of the Fiberline range. This machine stands out for its innovative **configuration of the cabin and beam, which move together during processing**. This solution leaves part of the worktable free, significantly simplifying material loading and unloading operations. The **EXPERT** is therefore the ideal choice for those seeking a compact, versatile, and efficient machine perfect for optimizing space and improving productivity in cutting operations.

| FIBERLINE EXPERT<br>Useful cutting | 15x30<br>5 ft x 10 ft            | 15x60<br>5 ft x 20 ft              | 20x40<br>6,5 ft x 13 ft            | 20x60<br>6,5 ft x 20 ft             |
|------------------------------------|----------------------------------|------------------------------------|------------------------------------|-------------------------------------|
| Area utile<br>Useful area          | 1500 x 3000 mm<br>(5 ft x 10 ft) | 1500 x 6000 mm<br>(5 ft x 20 ft)   | 2000 x 4000 mm<br>(6,5 ft x 13 ft) | 2000 x 6000 mm<br>(6,5 ft x 20 ft)  |
| Ingombro<br>Encumbrance            | 2750 x 5300 mm<br>(9 ft x 17 ft) | 2750 x 8700 mm<br>(9 ft x 28,5 ft) | 3400 x 6300 mm<br>(11 ft x 21 ft)  | 3400 x 8700 mm<br>(11 ft x 28,5 ft) |

### OPERATIONS

#### MARKING



#### LASER CUTTING

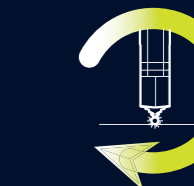

# FIBERLINE



## FIBERLINE RED

The machine has easy access in the front for standard maintenance operations and can be viewed internally through the front window, protected by certified glass.

The pallet change area is easily integrable with the most common and innovative sheet metal loading and unloading automation systems, whether single or multi-storage solutions.

Thanks to specific technological solutions, it is possible to leverage high-speed and precision performance ensured by high power output.

The CNC user interface, developed by Soitaab Impianti, allows even less experienced operators to manage the machine, supported by a comprehensive database of cutting parameters designed for a wide variety of metallic materials.

A monitoring display positioned above the CNC enables the operator to continuously oversee the machine's operations.

| FIBERLINE RED<br>Useful cutting | 15x30<br>5 ft x 10 ft                              | 20x40<br>6,5 ft x 13 ft                           | 20x60<br>6,5 ft x 19 ft                            | 25x60<br>8,2 ft x 19 ft                           | 25x120<br>8,2 ft x 39 ft                           |
|---------------------------------|--|---|--|---|--|
| Size                            | 8440 x 2270 x 2340 mm<br>(27 ft x 7,4 ft x 7,6 ft) | 10795 x 3191 x 2410 mm<br>(35,4 x 10,4 ft x 8 ft) | 14980 x 3191 x 2410 mm<br>(49 ft x 10,4 ft x 8 ft) | 14734 x 3781 x 2410 mm<br>(48,3 x 12,4 ft x 8 ft) | 27770 x 3781 x 2410 mm<br>(91 ft x 12,4 ft x 8 ft) |
|                                 |  |   |  |   |  |
|                                 |  |   |  |   |  |
|                                 |  |   |  |   |  |



### OPERATIONS

MARKING



LASER CUTTING

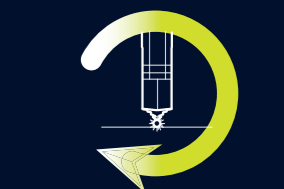

# FIBERLINE

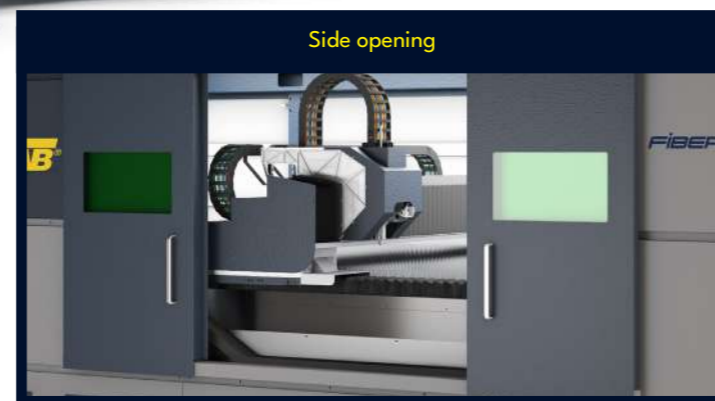

## FIBERLINE NOVA

The robust machine structure, combined with precise mechanical transmission configurations, ensures high cutting speed and precision, even on large work formats. The machine is accessible both from the front and the sides, thanks to a dual sliding door system designed for maintenance operations.

A series of side windows, protected by certified glass, allows external viewing of the machine's interior. The internal monitoring display, positioned above the CNC, enables the operator to continuously oversee two key areas of the machine: a general overview and a dedicated view of the cutting head.

The CNC user interface, developed by Soitaab Impianti, allows even less experienced operators to handle the machine with ease, supported by a comprehensive database of cutting parameters designed for a wide range of metallic materials.

| FIBERLINE NOVA  | 20x100                          | 20x120                            | 25x60                              | 25x80                              | 25x100                            | 25x120                              | 30x60                            | 30x80                             | 30x100                          | 30x120                            | 15x30                             | 20x40                            | 20x60                            | 20x80                             |
|---|---------------------------------|-----------------------------------|------------------------------------|------------------------------------|-----------------------------------|-------------------------------------|----------------------------------|-----------------------------------|---------------------------------|-----------------------------------|-----------------------------------|----------------------------------|----------------------------------|-----------------------------------|
| <b>Area utile</b> Useful cutting                      | 6,5 ft x 33 ft                  | 6,5 ft x 39 ft                    | 8 ft x 19 ft                       | 8 ft x 26 ft                       | 8 ft x 33 ft                      | 8 ft x 39 ft                        | 10 ft x 19 ft                    | 10 ft x 26 ft                     | 10 ft x 33 ft                   | 10 ft x 39 ft                     | 5 ft x 10 ft                      | 6,5 ft x 13 ft                   | 6,5 ft x 19 ft                   | 6,5 ft x 26 ft                    |
| Dimensione cabina<br>Cabin size                       | 3350 X 13445<br>(11 ft x 44 ft) | 3350 X 15685<br>(11 ft x 51,4 ft) | 3850 X 8965<br>(12,6 ft x 29,4 ft) | 3850 X 11205<br>(12,6 ft x 36 ft)  | 3850 X 13445<br>(12,6 ft x 44 ft) | 3850 X 15685<br>(12,6 ft x 51,4 ft) | 4850 X 8965<br>(16 ft x 29,4 ft) | 4850 X 11205<br>(16 ft x 36,7 ft) | 4850 X 13445<br>(16 ft x 44 ft) | 4850 X 15685<br>(16 ft x 51,4 ft) | 2850 X 5610<br>(9,3 ft x 18,4 ft) | 3350 X 6730<br>(11 ft x 22 ft)   | 3350 X 8965<br>(11 ft x 29,4 ft) | 3350 X 11205<br>(11 ft x 36,7 ft) |
| Altezza cabina<br>Cabin height                        | 2700<br>(9 ft)                  | 2700<br>(9 ft)                    | 2700<br>(9 ft)                     | 2700<br>(9 ft)                     | 2700<br>(9 ft)                    | 2700<br>(9 ft)                      | 2700<br>(9 ft)                   | 2700<br>(9 ft)                    | 2700<br>(9 ft)                  | 2700<br>(9 ft)                    | 2700<br>(9 ft)                    | 2700<br>(9 ft)                   | 2700<br>(9 ft)                   | 2700<br>(9 ft)                    |
| Dimensioni cambio pallet<br>Pallet changer dimensions | 3020 X 11040<br>(10 ft x 36 ft) | 3020 X 13140<br>(10 ft x 43 ft)   | 3520 X 6840<br>(11,5 ft x 22,4 ft) | 3520 X 8940<br>(11,5 ft x 29,3 ft) | 3520 X 11040<br>(11,5 ft x 36 ft) | 3520 X 13140<br>(11,5 ft x 43 ft)   | 4020 X 6840<br>(13 ft x 22,4 ft) | 4020 X 8940<br>(13 ft x 29,3 ft)  | 4020 X 11040<br>(13 ft x 36 ft) | 4020 X 13140<br>(13 ft x 43 ft)   | 2520 X 3690<br>(8 ft x 12 ft)     | 3020 X 4740<br>(10 ft x 15,5 ft) | 3020 X 6840<br>(10 ft x 22,4 ft) | 3020 X 8940<br>(10 ft x 29,3 ft)  |
| Altezza cambio pallet<br>Pallet changer height        | 1100<br>(3,6 ft)                | 1100<br>(3,6 ft)                  | 1100<br>(3,6 ft)                   | 1100<br>(3,6 ft)                   | 1100<br>(3,6 ft)                  | 1100<br>(3,6 ft)                    | 1100<br>(3,6 ft)                 | 1100<br>(3,6 ft)                  | 1100<br>(3,6 ft)                | 1100<br>(3,6 ft)                  | 1100<br>(3,6 ft)                  | 1100<br>(3,6 ft)                 | 1100<br>(3,6 ft)                 | 1100<br>(3,6 ft)                  |
| Peso<br>Weight  | 31.600 kg                       | 37.000kg                          | 23.800 kg                          | 29.300 kg                          | 35.550 kg                         | 35.550 kg                           | 26.100 kg                        | 30.200 kg                         | 39.500 kg                       | 47.200 kg                         | 11.000 Kg                         | 14.000 Kg                        | 21.000 kg                        | 25.400 kg                         |

### OPERATIONS

#### MARKING



#### LASER CUTTING



# FIBERLINE



|                           |                              |
|---------------------------|------------------------------|
| <b>FIBERLINE PRO</b>      | <b>15x30</b>                 |
| Area utile Useful cutting | 10 ft x 19 ft                |
| Area utile Useful area    | 3000x1500<br>(9,8 ft x 5 ft) |
| Ingombro Encumbrance      | 4500x2500<br>(15 ft x 8 ft)  |

## FIBERLINE PRO

Fiberline PRO is the ideal choice in terms of versatility and cost-effectiveness, providing the most advantageous cutting solution for a wide range of applications. With a compact yet sturdy structure, this machine offers high reliability. Its top-level performance is ensured by the use of state-of-the-art electronics and CNC systems. It features manual focus with a wider adjustment range.

An optional automatic tube feeding system can be provided for both input and output.

**OPERATIONS**

**LASER CUTTING**

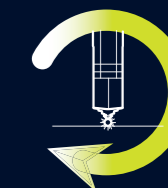

# OMNIA

PLASMA tech



## OMNIA NOVA 600

Plasma + drilling + threading + milling + marking + oxy-fuel cutting



## OMNIA NOVA 350

Plasma + drilling + threading + milling + oxy-fuel cutting



## OMNIA NOVA

**Omnia NOVA** represents the ideal synthesis between multifunctional technologies and combined systems, designed for processing any type of sheet or plate. This extremely versatile machine, equipped with multiple tools, is capable of performing a wide range of operations: thermal cutting, marking, drilling, threading, countersinking, and milling.

Its particularly robust structure, combined with cutting-edge technologies and a high-performance automated control system, ensures an excellent level of quality and precision in every machining process.

Omnia NOVA is available in two versions, designed to meet different production needs based on internal drilling capacity:

- **Omnia NOVA 350:** offers both transverse and vertical internal movement, making it ideal for drilling, threading, and milling operations on smaller work areas, with maximum precision.
- **Omnia NOVA 600:** designed for those who require greater operational capacity, the Omnia NOVA 600 significantly expands the working area compared to the 350, allowing easy management of larger and more complex projects.

### OPERATIONS

PLASMA



OXY



DRILLING

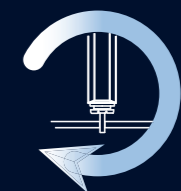

THREADING

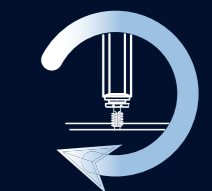

MILLING

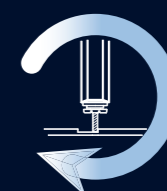

MARKING



COUNTERSINKING

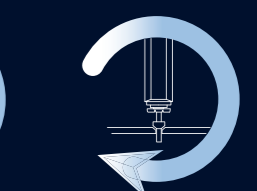

# OMNIA

LASER tech

**LASER** + plasma + **drilling EXTERNAL** + threading



**LASER** + plasma + **drilling INTERNAL** + threading + milling

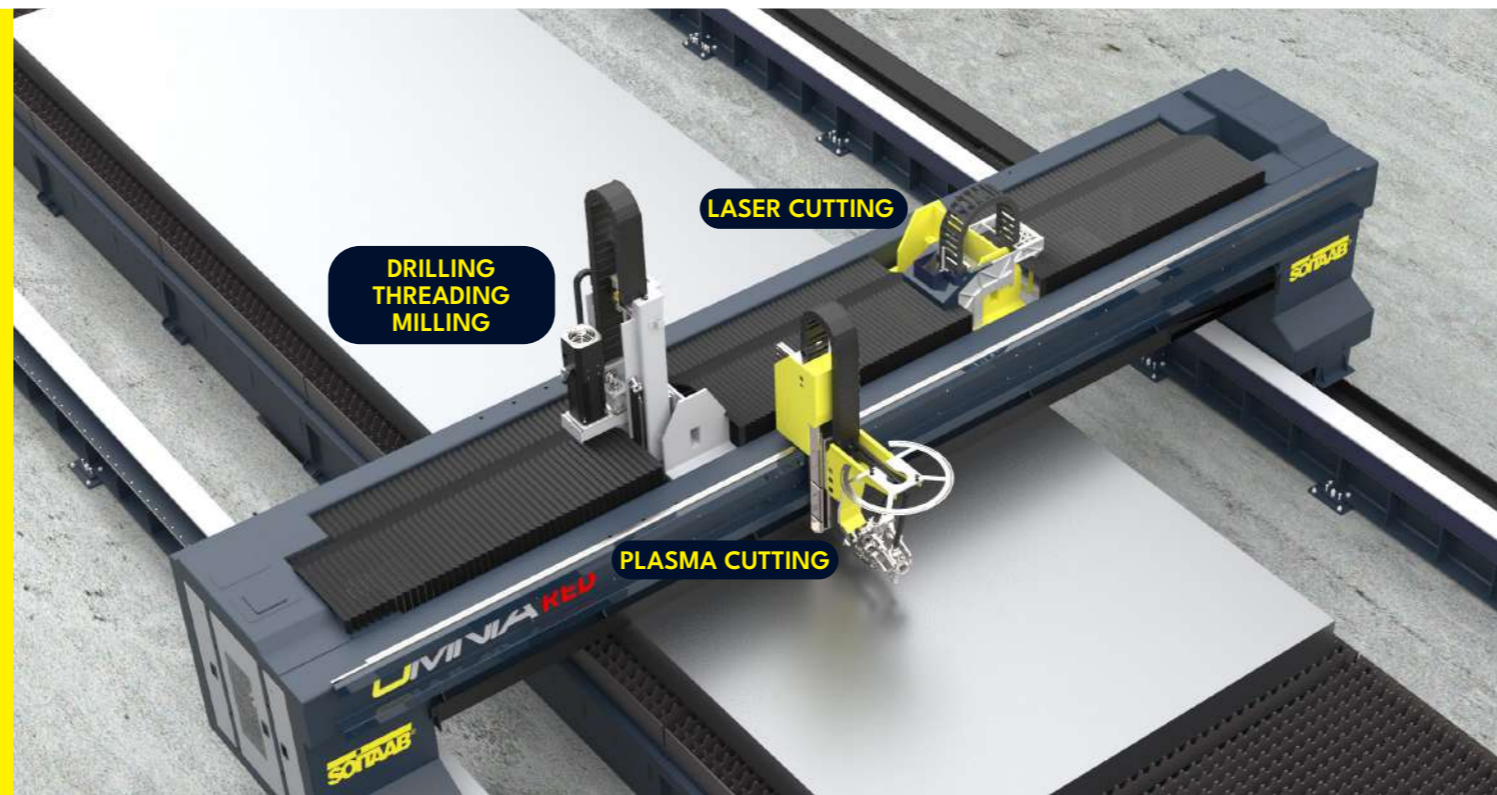
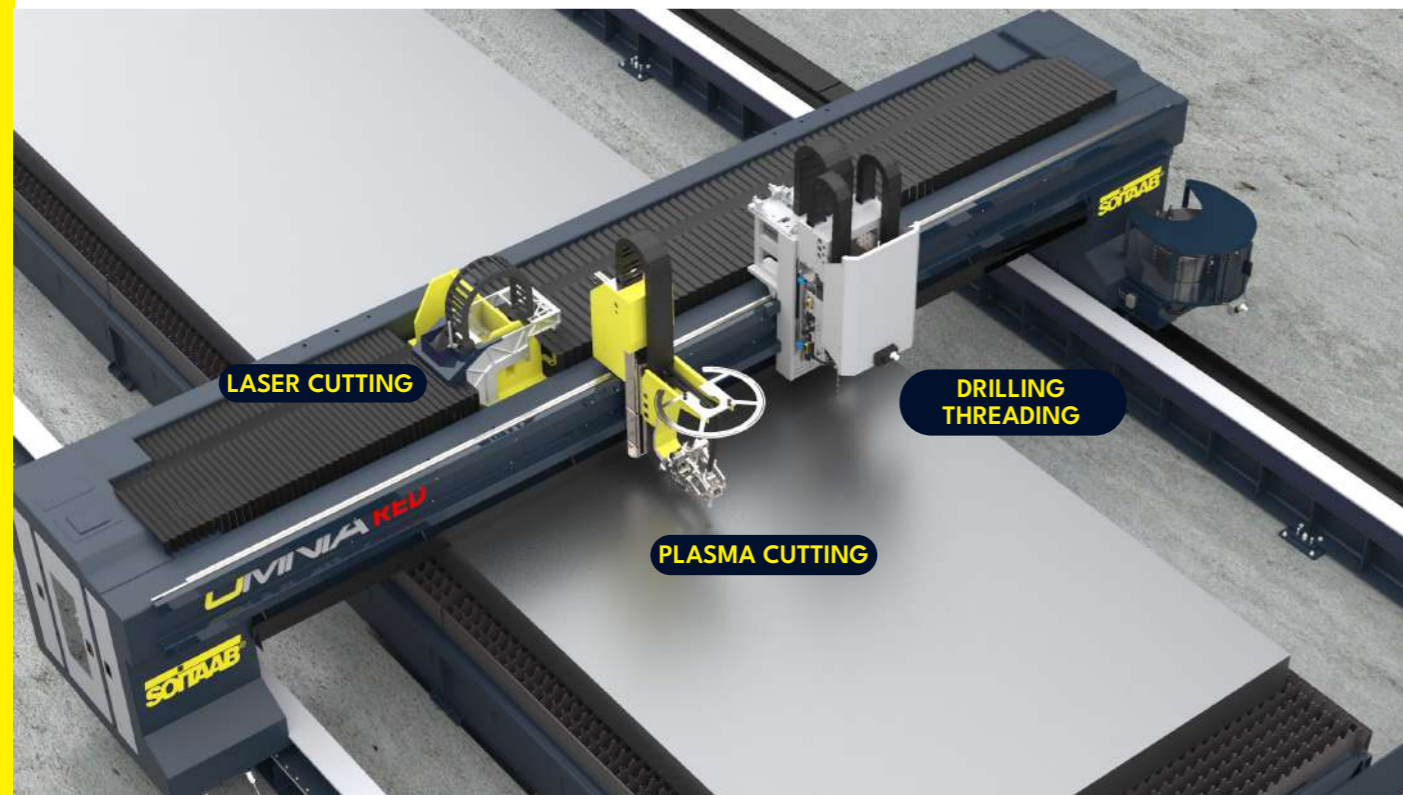

## OMNIA RED

The Omnia range is now expanded with Omnia RED, featuring the option to integrate laser cutting.

With this new integration, Omnia RED stands out as the ideal choice for every type of sheet and plate processing, meeting any production requirement with maximum flexibility and efficiency.

**OMNIA RED, with integrated laser cutting, is available in two versions:**

- With laser cutting, Bevel plasma cutting, drilling, and threading
- With laser cutting, plasma cutting, drilling, threading, and milling

OPERATIONS

LASER CUTTING

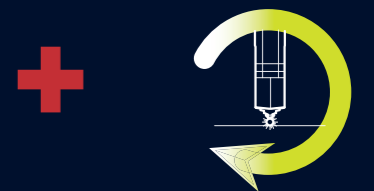

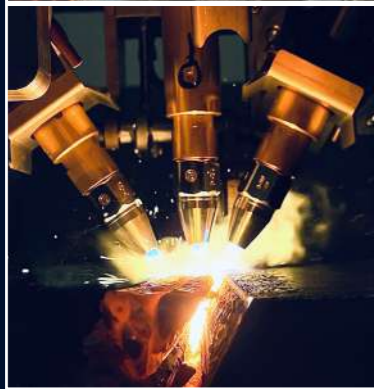

## LINEA PRO

Designed to meet the demands for high-quality and cost-effective thermal cutting, Linea PRO offers various application possibilities, including oxy-fuel cutting, plasma cutting, and marking.

Linea PRO can be equipped with up to 4 oxy-fuel torches and one plasma torch, with an effective cutting width of up to 3,000 mm (10 ft) and a carriage spacing of up to 4,000 mm (12 ft). An optional cutting parameter database enables fully automated gas management controlled by the CNC system.

Linea PRO features a robust structure and mechanical design suitable for integrating the most advanced high-definition cutting systems, ensuring optimal parameter management for superior cutting results, even on complex shapes and small diameter holes. The CNC II can be enhanced with a cutting parameter database for automatic management and includes a library of 30 fixed parametric shapes, which can be expanded to 78 shapes as an option.

Plasma systems are available with capacities up to 400 Amps.



## LINEA RED

Equipped with a dual-beam structure, dual longitudinal drives with Brushless motors, and digital drives with absolute coordinates, the Linea RED ensures smooth movement through a rack-and-pinion system with a backlash recovery device using a preloaded spring. It can be configured with up to 6 oxy-fuel torches and 2 plasma torches, with a carriage spacing of up to 5,500 mm (18.15 ft) and a maximum effective cutting width of 4,500 mm (14.8 ft).

A cutting parameter database enables fully automated gas management, controlled directly by the CNC system.

Linea RED supports the integration of the most advanced high-definition cutting systems, ensuring optimal parameter control for superior cutting results, even on complex shapes and small-diameter holes.

The Soitaab CNC, equipped with a cutting parameter database and a library of up to 78 fixed parametric shapes, makes this machine a high-performance solution for precision cutting tasks.

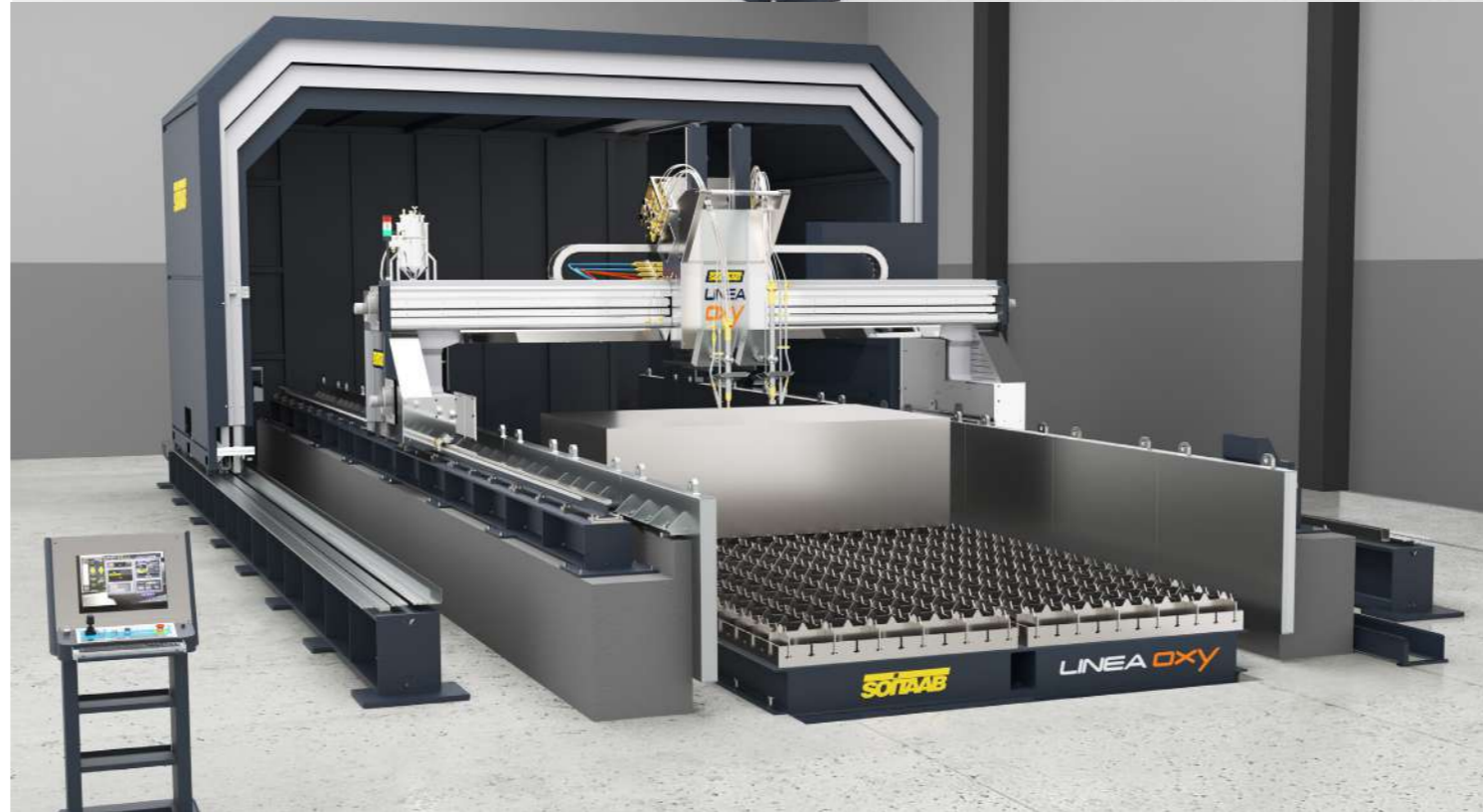

## LINEA OXY

The portal is properly designed and dimensioned to withstand high torsional stresses. The LINEATECH HT OXY has a double-beam structure: a front one, which has the function of carrying the transverse linear guides for the sliding of the tool-holder carriages, and a rear one, which has the function of stiffening the portal and maintaining the squareness of the whole system.

Unlike all the other lines, the LINEATECH HT OXY is equipped with a particle protection system consisting of a steel plate mounted under the beam to dissipate the heat produced by cutting, and a barrier made up of a separate steel plate mounted on each shoulder. Cutting capacity up to 1,000 mm thickness on carbon steel.

### OPERATIONS

MARKING



OXY



PLASMA



# LINEA tech

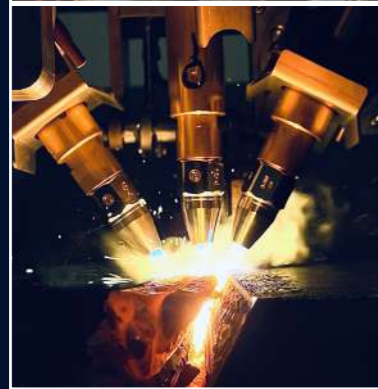

## LINEA NOVA

It offers a wide range of solutions for plasma cutting, oxy-fuel cutting, drilling/tapping, and marking. The gantry is a double-beam structure: a front beam where the transverse carriages move along two linear guides protected by a metal cover and arranged in an L-shape, and a rear beam for support and reinforcement. It can be equipped with bevel cutting heads for both plasma and oxy-fuel, drilling and tapping heads up to ISO50, tool changers, and various types of markers. Movement is achieved through a helical rack and pinion system with a backlash recovery device using a preloaded spring. The motors are absolute, meaning they retain the machine's position in memory even when powered off. The Linea NOVA covers cutting widths of up to 8,000 mm (26.25 ft) and lengths of up to 80,000 mm (262.50 ft). Oxyfuel torches are available with automatic ignition and internal or external capacitive sensors for automatic height control. The cutting parameter database developed by Soitaab ensures high cutting quality on parts and precise holes. The SOITAAB CNC II numerical control features a library of 78 parametric fixed shapes. Plasma generators are available with capacities of up to 800 Amps.

### OPERATIONS

PLASMA



OXY



DRILLING

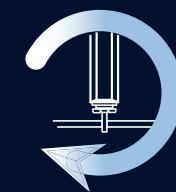

THREADING



MARKING



COUNTERSINKING

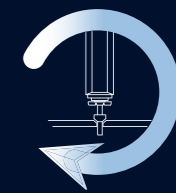

# PLASMA tech



| PLASMA PRO                    | 15x30              | 20x40            |
|-------------------------------|--------------------|------------------|
| Area utile Useful cutting     | 5 ft x 10 ft       | 6,5 ft x 13 ft   |
| Dimensione basamento          | 1960x4235          | 3460x5360        |
| Basement size                 | (6,5 ft x 14,1 ft) | (8 ft x 17,5 ft) |
| Altezza Height                | 1830 (6 ft)        | 1830 (6 ft)      |
| Larghezza portale Beam length | 2120 (7 ft)        | 2610 (9,8 ft)    |
| Peso Weight                   | 1900 kg            | 2500 kg          |

| PLASMA RED                    | 15x30              | 15x60              | 20x40              | 20x60              | 20x80              | 25x60              | 25x80              | 25x120           |
|-------------------------------|--------------------|--------------------|--------------------|--------------------|--------------------|--------------------|--------------------|------------------|
| Area utile Useful cutting     | 5 ft x 10 ft       | 5 ft x 20 ft       | 6,5 ft x 13 ft     | 6,5 ft x 20 ft     | 6,5 ft x 26,5 ft   | 8 ft x 20 ft       | 8 ft x 26,5 ft     | 8 ft x 39,4 ft   |
| Dimensione basamento          | 1987x4282          | 1987x7657          | 2487x5400          | 2487x7657          | 2487x9312          | 2987x7657          | 2987x9312          | 2987x13800       |
| Basement size                 | (6,6 ft x 14,8 ft) | (6,6 ft x 24,7 ft) | (8,3 ft x 18,5 ft) | (8,3 ft x 24,7 ft) | (8,3 ft x 31,4 ft) | (9,9 ft x 24,7 ft) | (9,9 ft x 31,4 ft) | (9,9 ft x 45 ft) |
| Altezza Height                | 2100 (7 ft)        | 2100 (7 ft)        | 2100 (7 ft)        | 2100 (7 ft)        | 2100 (7 ft)        | 2100 (7 ft)        | 2100 (7 ft)        | 2100 (7 ft)      |
| Larghezza portale Beam length | 2478 (8,2 ft)      | 2478 (8,2 ft)      | 2978 (9,8 ft)      | 2978 (9,8 ft)      | 2978 (9,8 ft)      | 3478 (11,5 ft)     | 3478 (11,5 ft)     | 3478 (11,5 ft)   |
| Peso Weight                   | 3150 Kg            | 4550 Kg            | 4650 Kg            | 8750 kg            | 11650 Kg           | 10750 kg           | 14350 Kg           | 10100 Kg         |

## PLASMA RED

The true “plug-and-play” plasma solution that offers top-tier quality, with easy to use and quick to learn functionality, for the quickest operational readiness. Designed for cutting ferrous materials, stainless steel, and aluminum, it is suitable for medium/thin sheet thicknesses and sheet dimensions up to 2.5 m (8.2 ft) in width and 12 m (39.4 ft) in length. Plasma Red is widely used in metal fabrication workshops and the sheet metal processing sector for air ducting.

The numerical control system, equipped with the H.M.I interface (Soitaab Human Machine Interface) specifically developed for the RED model, enables even less experienced operators to fully utilize the machine’s advanced capabilities. Positioning precision is ensured by the robust gantry structure, dual longitudinal brushless motors with gantry axis control, precision-ground linear guides with double ball recirculation carriages, rack and pinion systems, and an independent worktable separated from the machine’s guiding structure.

Special attention has been given to the protection of all guides and compliance with safety regulations, making Plasma Red a safe and reliable machine. The dedicated generator for Plasma RED is designed for high-definition cutting (XD and XPR).

## PLASMA PRO

The Plasma Pro is the entry-level plug-and-play version of the Plasmatech family. Versatile and cost-effective, it represents the most advanced cutting solutions for many applications. This highly reliable machine features compact dimensions combined with a robust structure. It delivers high-level performance thanks to state-of-the-art electronics and CNC technology. Equipped with AVC, anti-collision, UV protection, diode laser, and “Touch and Go” initial positioning sensing, it is ideal for initial positioning on both thin and medium-thickness sheets.

### OPERATIONS

#### MARKING



#### PLASMA



# PLASMA tech

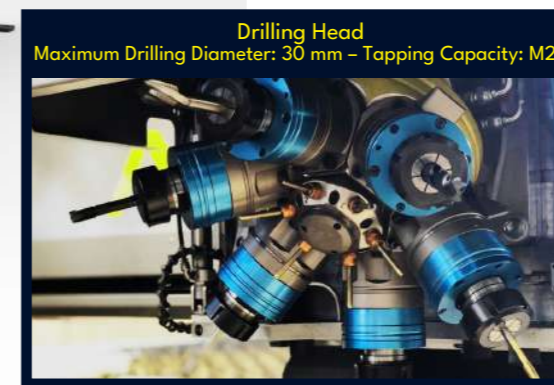
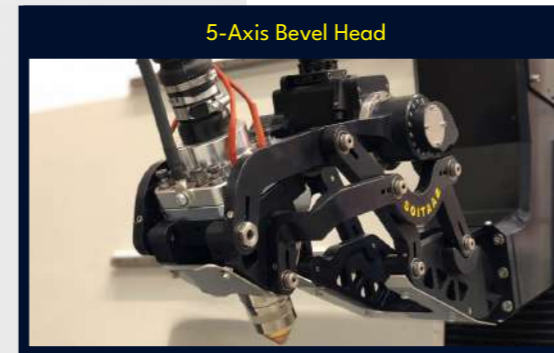

## PLASMA NOVA

Plasma NOVA integrates multiple technologies and features to meet the most complex production requirements.

It enables complex operations to be performed in a single setup, thus optimizing the production cycle.

Designed for cutting ferrous materials, stainless steel, and aluminum, it is particularly suitable for medium to heavy thickness cutting and can be equipped with a wide range of accessories.

The robust machine structure is engineered to maximize operational performance, even under the most demanding working conditions.

The positioning precision is ensured by the dual longitudinal brushless motorization with gantry axis control, precision-ground linear guides with double ball recirculation sliders, and helical rack-and-pinion systems with downward-facing profiles.

Special attention has been given to the protection of all guides and compliance with safety regulations, making **Plasma NOVA** the safest machine on the market.

| PLASMA NOVA                           | 20x40                       | 20x60                         | 20x80                        | 25x60                          | 25x80                         | 25x120                        | 30x60                          | 30x80                         | 30x120                        |
|---------------------------------------|-----------------------------|-------------------------------|------------------------------|--------------------------------|-------------------------------|-------------------------------|--------------------------------|-------------------------------|-------------------------------|
| Area utile Useful cutting             | (6,5 ft x 13 ft)            | (6,5 ft x 20 ft)              | (6,5 ft x 26,5 ft)           | (8 ft x 20 ft)                 | (8 ft x 26,5 ft)              | (8 ft x 39,5 ft)              | (10 ft x 20 ft)                | (10 ft x 26,5 ft)             | (10 ft x 39,5 ft)             |
| Dimensione basamento<br>Basement size | 2700x5750<br>8,9 ft x 19 ft | 2700x8000<br>8,9 ft x 26,4 ft | 2700x10250<br>8,9 ft x 32 ft | 3200x8000<br>10,5 ft x 26,4 ft | 3200x10250<br>10,5 ft x 32 ft | 3200x13600<br>10,5 ft x 45 ft | 3700x8000<br>12,2 ft x 26,4 ft | 3700x10250<br>12,2 ft x 32 ft | 3700x13600<br>12,2 ft x 45 ft |
| Altezza Height                        | 2100 (8 ft)                 | 2100 (8 ft)                   | 2100 (8 ft)                  | 2100 (8 ft)                    | 2100 (8 ft)                   | 2100 (8 ft)                   | 2100 (8 ft)                    | 2100 (8 ft)                   | 2100 (8 ft)                   |
| Larghezza portale Beam<br>length      | 3350 (11 ft)                | 3350 (11 ft)                  | 3350 (11 ft)                 | 3850 (12,6 ft)                 | 3850 (12,6 ft)                | 3850 (12,6 ft)                | 4350 (14,2 ft)                 | 4350 (14,2 ft)                | 4350 (14,2 ft)                |
| Peso Weight                           | 4590 kg                     | 6410 kg                       | 8230 kg                      | 7925 kg                        | 10200 kg                      | 14750 kg                      | 9440 kg                        | 12170 kg                      | 17630 kg                      |

### OPERATIONS

PLASMA



OXY



DRILLING

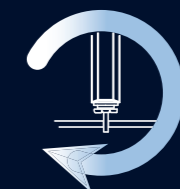

THREADING



MARKING



# WATERJET



## WATERLINE

**Waterline** is the result of years of experience in the design and manufacturing of waterjet cutting machines. Constantly evolving, the entire range of Soitaab **Water-Tech** products represents the synthesis of cutting-edge innovations and advanced software solutions. Soitaab owns the proprietary cutting technology tables, developed and tested in-house, a well-established know-how that is shared with customers, providing them with this valuable expertise.

Every detail of the **Waterline** is carefully crafted, from an attractive design to meticulous attention in selecting top-quality components readily available in the global market.

Special care is given to the protection of all mechanical parts, making this machine fully safeguarded and perfectly suited to operate in harsh environments typical of waterjet cutting systems.

## DUALINE

**Dualine** combines two cutting technologies in a single machine: Plasma and Water Jet. The result is a machine that simultaneously meets both productivity and precision requirements, allowing various cutting combinations on the same workpiece.

### OPERATIONS

MARKING



PLASMA



WATERJET



| WATERLINE/DUALINE<br>Area utile Useful cutting | 15x15<br>(5 ft x 5 ft)       | 30x15<br>(10 ft x 5 ft)       | 30x20<br>(10 ft x 6,5 ft)     | 40x20<br>(13 ft x 6,5 ft)   | 20x40<br>(6,5 ft x 13 ft)      | 20x60<br>(6,5 ft x 20 ft)    | 20x80<br>(6,5 ft x 23,5 ft)    | 30x60<br>(10 ft x 19,7 ft)   | 30x80<br>(10 ft x 26,2 ft)      | 30x120<br>(10 ft x 39,4 ft)   |
|--|------------------------------|-------------------------------|-------------------------------|-----------------------------|--------------------------------|------------------------------|--------------------------------|------------------------------|---------------------------------|-------------------------------|
| Dimensione basamento<br>Basement size          | 2300x2300<br>7,6 ft x 7,6 ft | 4135x2300<br>13,6 ft x 7,6 ft | 4135x2800<br>13,6 ft x 9,2 ft | 5135x2800<br>17 ft x 9,2 ft | 3100x5300<br>10,2 ft x 17,4 ft | 3100x7300<br>10,2 ft x 24 ft | 3100x9300<br>10,2 ft x 27,3 ft | 4135x8500<br>13,6 ft x 28 ft | 4135x10500<br>13,6 ft x 34,5 ft | 5135x14500<br>17 ft x 47,6 ft |
| Altezza Height                                 | 1600 (5,3 ft)                | 1600 (5,3 ft)                 | 1600 (5,3 ft)                 | 1600 (5,3 ft)               | 1600 (5,3 ft)                  | 1600 (5,3 ft)                | 1600 (5,3 ft)                  | 1600 (5,3 ft)                | 1600 (5,3 ft)                   | 1600 (5,3 ft)                 |
| Larghezza portale Beam length                  | 2.515 (8,3 ft)               | 4350 (14,3 ft)                | 4350 (14,3 ft)                | 5350 (17,5 ft)              | 3300 (11 ft)                   | 3300 (11 ft)                 | 3300 (11 ft)                   | 4350 (14,3 ft)               | 4350 (14,3 ft)                  | 5135 (17 ft)                  |
| Peso Weight                                    | 2500 kg                      | 3500 kg                       | 4500 kg                       | 4700 kg                     | 7100 kg                        | 10500 kg                     | 13500 kg                       | 10000 kg                     | 12500 kg                        | 19500 kg                      |

# TUBOCUT



| Model                           | 400V/50HZ                              |
|---------------------------------|--|
| <b>LASER TUBOCUT</b>            |  |
| Total Weight                    | 4500KG                                 |
| Size                            | 12700*1880*2630 mm<br>(41.6*6*8.6 ft)  |
| Available Power                 | 1000-6000W                             |
| Y-Axis Travel                   | 6500mm (21.32 ft)                      |
| X-Axis Travel                   | 330mm (1.1 ft)                         |
| Z-Axis Travel                   | 350mm (1.14 ft)                        |
| X/Y-Axis Positioning Accuracy.  | ±0.05mm (0.02 ft)                      |
| X/Y-Axis Repositioning Accuracy | ±0.03mm (0.01 ft)                      |
| X-Axis Maximum Travel Speed     | 40 m/min                               |
| Y-Axis Maximum Travel Speed     | 30 m/min                               |
| Maximum Acceleration            | 0.6 g                                  |
| Maximum Working Capacity        | 116 kg/m                               |
| Maximum Rotational Speed        | 60 rpm                                 |
| Maximum feeding Speed           | 60 m/min                               |
| Bevel swing angle               | ±45°                                   |
| Length                          | 6500mm o 12500 mm<br>(21.3 ft o 41 ft) |
| Diameter for Tubes              | 120--240mm<br>(10.06--0.8 ft)          |
| Tube Length                     | 6m o 12 m<br>(19.7 ft o 39.4 ft)       |
| Transmission                    | Rack and Pinion                        |

## LASER TUBOCUT

The **TUBOCUT Laser** is designed for cutting and processing round, square, and rectangular tubes, and can be configured according to various cutting requirements. It is equipped with a **spindle for tube processing** that moves longitudinally, a **pneumatic spindle guide**, a **tube support with longitudinal jaws**, and a cut tube unloading system featuring a sliding table and a container for collecting the cut pieces. The machine is fitted with a **Precitec cutting head with automatic focus adjustment**. The software automatically controls the focusing mirror to regulate the laser head height at high speed, offering a wider adjustment range compared to manual focusing. Optionally, an **automatic tube feeding system** can be supplied for both the loading and unloading sides.

## PLASMA TUBOCUT

The **Plasma TUBOCUT** is suitable for cutting round, square, and rectangular tubes. It can be configured as either **manual or automatic**, and equipped according to different cutting requirements. In addition, the **automatic Plasma TUBOCUT** features a **longitudinal roller conveyor** for tube support, which is **automatically adjustable in height**. It is composed of a series of **double rollers with manual positioning** and offers a **maximum load capacity of 250 kg per meter**.

### OPERATIONS

MARKING



LASER CUTTING

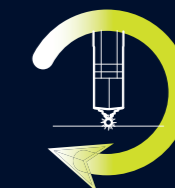

PLASMA



**BANDSAW**  
**FRIGGI** SOTRAB



## STEEL solutions



## ALUMINIUM solutions



## PRODUCTION AREA

MECHANICAL PROCESSING - ASSEMBLY

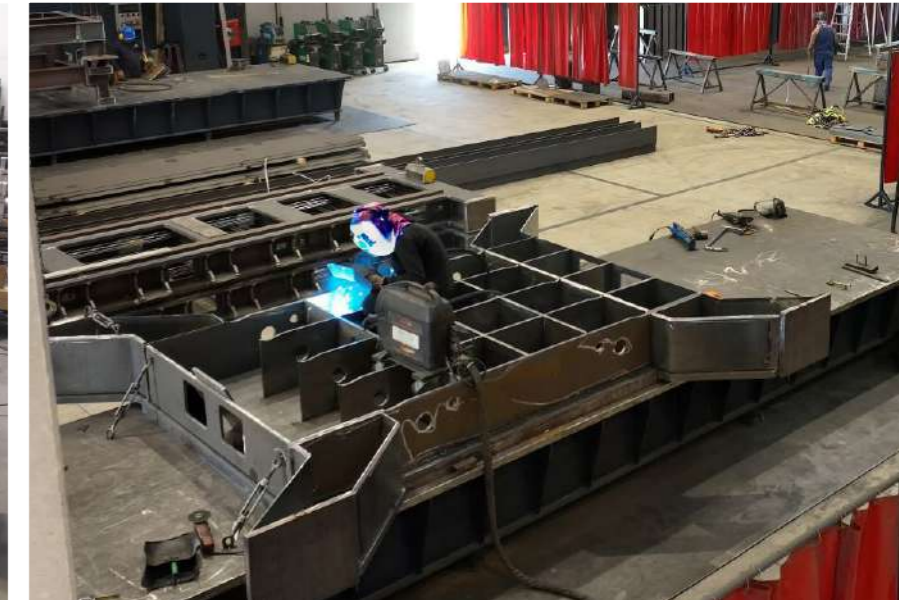



Soitaab France SARL  
19 Rue du clos de la vigne  
49220 Thorigné d'Anjou - France  
[info@soitaab.fr](mailto:info@soitaab.fr)  
Ph:+33 6 17 71 98 92

**SOITAAB Impianti srl**  
**Via del Lavoro, 9**  
**20061 Carugate (MI) - Italia**  
**Ph +390292504044**  
**[contacts@soitaab.com](mailto:contacts@soitaab.com)**  
**[www.soitaab.com](http://www.soitaab.com)**

SOITAAB USA Inc.  
30W141 Wheeler Circle  
Warrenville, IL 60563  
Ph +1 630 447 7004  
[info@soitaab.us](mailto:info@soitaab.us)  
[www.soitaabusa.com](http://www.soitaabusa.com)

Products  
Overview

